

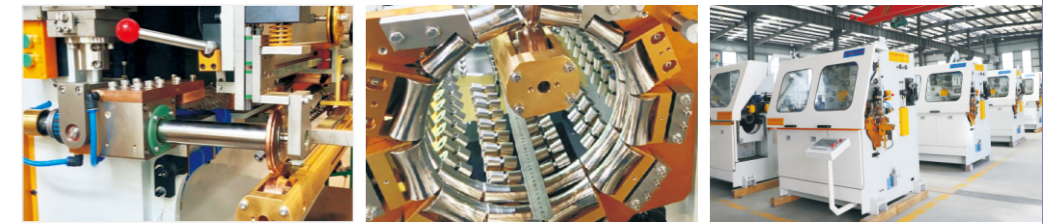

總經理:
General manager

手機: +86-15982829210
Mobile

地址Add: No. 335, Xinpu Road, Shou 'an Industrial Park,
Pujiang, Chengdu, Sichuan Province, China
電話Tel: 028-82666281
Email: cdctzg@vip.sina.com
Personal E-mail: 15982829210@139.com
郵編Postcode: 611633
網址Website: <http://www.changtaizn.cn/>
<https://www.ctcanmachine.com/>



真诚服务 创新致远
SINCERITY AND INNOVATION



成都市昶泰智能設備有限公司
Chengdu Changtai Intelligent Equipment Co., Ltd.

公司地址: 四川省成都市蒲江縣壽安街道新蒲路335號
No. 335, Xinpu Road, Shouan Street, Pujiang
County, Chengdu, Sichuan Province, China

網站: <http://www.changtaizn.cn/>
<http://www.ctcanmachine.com/>



國內官網: <http://www.changtaizn.cn/>



Google website: <https://www.ctcanmachine.com/>

CORPORATE BROCHURE

企业宣传手册

成都市昶泰智能設備有限公司
Chengdu Changtai Intelligent Equipment Co., Ltd.



CONTENTS

目录



企业介绍	INTRODUCTION	001
企业文化	CULTURE	003
技术实力	TECHNICAL STRENGTH	005
生产实力	PRODUCTIVE STRENGTH	007
企业荣誉	ENTERPRISE HONOR	009
优势	ADVANTAGE	011
产品信息	PRODUCT	013
合作伙伴	COOPERATIVE PARTNER	031

ENTERPRISE INTRODUCTION

企业介绍

成都市昶泰智能设备有限公司，地处美丽富饶、人杰地灵的“天府之国”成都。公司成立于2007年，是一家引进国外先进制罐技术、汇聚制罐设备行业精英、结合国内金属制罐行业需求和特点，专业从事研发，生产及销售全自动制罐设备，同时承接半自动制罐设备和杂罐设计技术改造服务的科技型民营企业。

公司占地面积8000平方米，拥有先进的加工和生产设备，拥有专业研发人员10人，生产及售后服务人员50多人，为研究，生产，交付及售后服务提供了强有力的保障。主要生产全自动罐身变频缝焊机及后进料半自动变频缝焊机，被广泛应用于印刷制罐、食品罐子、乳制品包装、压力容器、化工油漆、电力电容器等相关行业上。

成都昶泰与国内多家企业建立了长期的合作关系，并远销东南亚、中东、非洲、英国等国家和地区，产品深受国内外客户的好评。

成都昶泰热烈欢迎各界朋友前来参观、考察、洽谈业务。

Chengdu Changtai can manufacture equipment co.,ltd. is located in the Chengdu city, beautiful and rich in natural resources.The company was founded in 2007,is a science and technology private enterprise,having advanced foreign technology and high quality equipment. We combined the domestic industrial demand character, specializing in research,development,production and sales of automatic can equipment, as well as the semi-automatic can making equipment,etc.

The company covers an area of 5000 square meters,own the advanced processing and production equipment, there are professional research and development personnel 10 people,production and after-sales service more than 50 people,furthermore,the R&D manufacturing department provides a powerful guarantee for the advanced research, production and well after-sales service. We specialize in manufacturing of automatic can body welding machine and semi-automatic backward seam welding machine, which is widely used for the canned food,dairy products packaging,presure vessel, chemical paint, electric power industry etc.

We cooperate with many domestic enterprises for several years,and our products sold well in domestic and oversea markets, enjoying high public praise.

We are looking forward to your visit for further negotiation and cooperation.

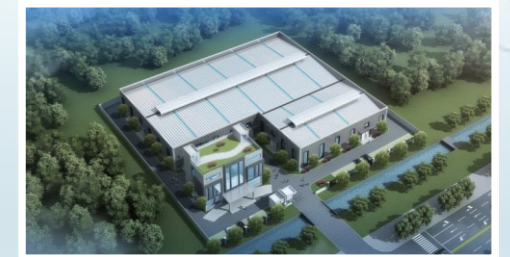

CULTURE 企业文化

公司秉承以人为本的管理精神，坚持诚信务实、科技为先、创新高效、顾客满意的经营理念，以至于推动行业发展，为制罐标准化和自动化不懈努力，帮助客户实现了低投入、高产出，高效能的经营目标，为客户及社会带来更多的经济效益。

Our company always persists in the people-oriented management spirit, adhere to Honest Pragmatic philosophy, devoting to promote the development of the can-making industry for standardization and automation. We help customers realize a high yields with low investment, achieve the goal of efficient management, and bring them more economic benefits. We cooperate with many domestic enterprises for several years, and our products sold well in domestic and oversea markets, enjoying high public praise.

真诚服务 创新致远
SINCERITY AND INNOVATION

TECHNICAL STRENGTH

技术实力

公司凝聚了一批由高级机械工程师、高级电气工程师、高级技师等组成的年富力强的具备专业素质的精英，工程师。同时配合公司客户的需要，我们拥有50多名经验丰富的售后服务工程师，可以随时为世界各地的客户提供快速，优质的维修及售后服务。同时拥有多个生产线运行团队，可以为客户提供生产线的生产指导、培训以及运营管理服务。

Our company has gathered a group of senior mechanical engineers, senior electrical engineers, senior technicians and so on composed of young and strong elite with professional quality, engineers. At the same time to meet the needs of the company's customers, we have more than 50 experienced after-sales service engineers, can provide customers around the world with fast, quality maintenance and after-sales service at any time. It also has multiple production line operation teams, which can provide production guidance, training and operation management services for customers.



PRODUCTIVE STRENGTH

生产实力

公司现拥有生产厂房共计 8千多平米，拥有全套的锯床、车床、钻床、铣床、磨床及加工中心设备。具备从原材料开始加工直至产品装配的全套生产体系，每一道环节都拥有完善的质量管控体系，有效的保证了产品的质量和稳定性。

The company now has a total of more than 8,000 square meters of production plants, with a full set of sawing machines, lathes, drilling machines, milling machines, grinding machines and processing center equipment. With a full set of production system from raw material processing to product assembly, each link has a perfect quality control system, effectively ensure the quality and stability of products.

 **8000** m²

公司拥有生产厂房共计8000多平方米
Company has more than 8000m² workshop



ENTERPRISE HONOR 企业荣誉

公司拥有多个自有专利证书，主要设备均拥有CE证书，同时获得高新技术企业证书。

The company has a number of own patent certificates, the main equipment have CE certificate, at the same time to obtain the high-tech enterprise certificate.

高新技术企业证书 High-tech industry certificate



CE证书 CE certificate



专利证书 Patent certificate



ADVANTAGE 优势

Professional Team 专业团队



专业的技术团队，研发团队，生产和售后团队，可实现全程跟踪服务，一对一服务，为您提供合适的解决方案。

Professional technical team, R&D team, production and after-sales team can achieve full tracking service, one-to-one service, and provide suitable solutions for you.

Quality Assurance 质量保证



我们的机械配件及零部件均为国内外知名品牌，每台设备均有1年保修期，消除您的后顾之忧。

Our mechanical accessories and parts are all well-known brands at home and abroad, and each equipment has a 1-year warranty period to eliminate your worries.

Independent R&D 自主研发



公司拥有一支专业的研发团队，均拥有20年以上罐头机械行业经验，并获得多项实用专利证书。

The company has a professional R&D team, all of whom have more than 20 years of experience in the canning machinery industry, and have obtained a number of practical patent certificates.

Factory Supply 工厂供应



拥有占地面积8000多平方米的工厂生产基地，先进的加工生产设备，可同时供应多条生产线。

With a factory production base covering an area of more than 8,000 square meters, advanced processing and production equipment, multiple production lines can be supplied at the same time.

ODM&OEM 定制



我们的设计开发团队可以完美解决制罐机械设备的独特生产需求和设计。

The unique production needs and design of can making machinery and equipment can be perfectly solved by our design and development team.

Perfect after-sale 完美售后



我们拥有高效的售后服务团队，为您提供24小时一对一服务，并有专门的技术售后团队，与您的工程师直接对接，进行有效沟通。

We have an efficient after-sales team to provide you with 24-hour service one-on-one and a dedicated technical after-sales team to directly connect with your engineers and communicate effectively.

AUTOMATIC CAN BODY WELDING MACHINE 全自动罐身变频缝焊机

适用于气雾罐、食品罐等罐身的焊接
Apply to the welding of various can, such as food cans, Aerosal cans

可与罐身内、外补涂机和罐身烘干机配套成线

Can body internal and external pre-painting machine and can body drier are optional to be added in production line

可根据客户需求加快速度

According to customer's demand to accelerate the speed.



FH18-52ZD



Technical Parameters产品参数产品专利号: 20222096 8273.5

型号 Model	FH18-52ZD-100	FH18-52ZD-200	FH18-52ZD-300
订货号 Order number	FH1852ZD100	FH1852ZD200	FH1852ZD300
焊接速度 Welding Speed	15-30m/min	20-36m/min	30-45m/min
生产速度 Production Capacity	50-100cans/min	100-200cans/min	200-300cans/min
适应罐径范围 Can Diameter Range	φ 52- φ 99mm		
适应罐高范围 Can Height Range	70-320mm	70-280mm	55-200mm
适应罐身材料 Material	Tinplate 镀锡板 Steel-based 钢基板 Galvanized sheet 镀锌板		
适应罐身板厚 Tinplate Thickness Range	0.16-0.3mm		
铜线直径 Applicable copper Wire Diameter	φ 1.38mm		
冷却水 Cooling Water	Temperature :<=20°C Pressure:0.4-0.5Mpa/m² Discharge:10L/min		
电源 Power Supply	380V±5% 50Hz		
焊接功率 Total Power	40KVA	60KVA	80KVA
尺寸 Machine Dimension	2100*1600*1900mm		
重量 Weight	2500kg		

样图仅供参考, 实物、参数如有变动恕不通知, 可按客户要求定制产品
Sample figure is only for reference, such as physical parameters, otherwise are subject to change without notice is just for your reference.

AUTOMATIC CAN BODY WELDING MACHINE 全自动罐身变频缝焊机

适用于食品罐、油墨罐等罐身的焊接
Apply to the welding of various can, such as Food cans, ink cans

可与罐身内、外补涂机和罐身烘干机配套成线

Can body internal and external pre-painting machine and can body drier are optional to be added in production line

可根据客户需求加快速度

According to customer's demand to accelerate the speed.



FH18-65ZD



Technical Parameters产品参数产品专利号: 20222096 8273.5

型号 Model	FH18-65ZD-100	FH18-65ZD-200	FH18-65ZD-300
订货号 Order number	FH1865ZD100	FH1865ZD150	FH1865ZD200
焊接速度 Welding Speed	15-30m/min	20-36m/min	30-45m/min
生产速度 Production Capacity	50-100cans/min	100-200cans/min	200-300cans/min
适应罐径范围 Can Diameter Range	φ 65- φ 180mm		
适应罐高范围 Can Height Range	70-320mm	70-280mm	55-200mm
适应罐身材料 Material	Tinplate 镀锡板 Steel-based 钢基板 Galvanized sheet 镀锌板		
适应罐身板厚 Tinplate Thickness Range	0.16-0.3mm		
铜线直径 Applicable Dopper Wire Diameter	φ 1.38mm φ 1.5mm		
冷却水 Cooling Water	Temperature :<=20°C Pressure:0.4-0.5Mpa/m² Discharge:10L/min		
电源 Power Supply	380V±5% 50Hz		
焊接功率 Total Power	40KVA	60KVA	80KVA
尺寸 Machine Dimension	2100*1600*1900mm		
重量 Weight	2500kg		

样图仅供参考, 实物、参数如有变动恕不通知, 可按客户要求定制产品
Sample figure is only for reference, such as physical parameters, otherwise are subject to change without notice is just for your reference.

AUTOMATIC CAN BODY WELDING MACHINE 全自动罐身变频缝焊机

适用于食品罐、油墨罐、方便罐等罐身的焊接。

Apply to the welding of various can, such as Food cans, ink cans, convenience cans.

可与罐身内、外补涂机和罐身烘干机配套成线。

Can body internal and external pre-painting machine and can body drier are optional to be added in production line.

可根据客户需求加快速度。

According to customer's demand to accelerate the speed.



FH18-65ZDS



Technical Parameters产品参数 产品专利号: 20222096 8273.5

型号 Model	FH18-65ZDS
订货号 Order number	FH1865ZDS02
焊接速度 Welding Speed	6-26m/min
生产速度 Production Capacity	40-100cans/min
适应罐径范围 Can Diameter Range	φ 65- φ 180mm
适应罐高范围 Can Height Range	60-320mm
适应罐身材料 Material	Tinplate 镀锡板 Steel-based 钢基板 Galvanized sheet 镀锌板
适应罐身板厚 Tinplate Thickness Range	0.2-0.35mm
缝焊搭接量 Z-bar Overlap Range	0.4mm 0.6mm 0.8mm
铜线直径 Applicable Copper Wire Diameter	φ 1.38mm φ 1.5mm
冷却水 Cooling Water	温度 Temperature: ≤20℃ 压力 Pressure: 0.4-0.5Mpa/m² 流量 Discharge: 10L/min
电源 Power Supply	380V±5% 50Hz
焊接功率 Total Power	60KVA
尺寸 Machine Measurements	1750*1100*1800mm
重量 Weight	2500KG

样图仅供参考, 实物、参数如有变动恕不通知, 可按客户要求定制产品
Sample figure is only for reference, such as physical parameters, otherwise are subject to change without notice is just for your reference.

AUTOMATIC CAN BODY WELDING MACHINE 全自动罐身变频缝焊机

适用于彩印覆膜桶、花兰桶、方便桶等罐身的焊接

Apply to the welding of various can, such as color printing coated cans, flower orchid cans, convenient cans and so on

可与罐身内、外补涂机和罐身烘干机配套成线

Can body internal and external pre-painting machine and can body drier are optional to be added in production line



FH18-90ZD-60/60L



Technical Parameters产品参数 产品专利号: 20222096 8273.5

型号 Model	FH18-90ZD-60	FH18-90ZD-60L
订货号 Order number	FH1890ZD6003	FH1890ZD60L03
焊接速度 Welding Speed	6-24m/min	
生产速度 Production Capacity	20-60cans/min	
适应罐径范围 Can Diameter Range	φ 220- φ 300mm	
适应罐高范围 Can Height Range	250-450mm	250-500mm
适应罐身材料 Material	Tinplate 镀锡板 Iron Substrate 钢基板 Galvanized sheet 镀锌板	Tinplate 镀锡板 Steel-based 钢基板 Galvanized sheet 镀锌板 Chrome plate 镀铬板
适应罐身板厚 Tinplate Thickness Range	0.25-0.42mm	
缝焊搭接宽度 Z-bar Overlap Range	0.6mm	0.8mm 1.0mm
焊接点距 Nugget Distance	0.5-0.8mm	
频率范围 Frequency Range	100-260Hz	
铜线直径 Applicable copper wire diameter	φ 1.5mm φ 1.8mm	
冷却水 Cooling Water	温度 Temperature: 12-18℃ 压力 Pressure: 0.4-0.5Mpa/m² 流量 Discharge: 12L/min	
压缩空气消耗量 Compressed Air Consumption	400L/min	
空气压力 Pressure	0.5Mpa/m²-0.7Mpa/m²	
电源 Power Supply	380V±5% 50Hz	
焊接功率 Total Power	150KVA	
尺寸 Machine Measurements	2450*1800*2000mm	
重量 Weight	4200kg	

样图仅供参考, 实物、参数如有变动恕不通知, 可按客户要求定制产品
Sample figure is only for reference, such as physical parameters, otherwise are subject to change without notice is just for your reference.

AUTOMATIC CAN BODY WELDING MACHINE 全自动罐身变频缝焊机

适用于彩印覆膜桶、花兰桶、方便桶等罐身的焊接

Apply to the welding of various can, such as color printing coated cans, flower orchid cans, convenient cans and so on

可与罐身内、外补涂机和罐身烘干机配套成线

Can body internal and external pre-painting machine and can body drier are optional to be added in production line



FH18-90ZD-42/42L

Technical Parameters 产品参数 产品专利号: 20222096 8273.5

型号 Model	FH18-90ZD-42	FH18-90ZD-42L
订货号 Order number	FH1890ZD4201	FH1890ZD42L02
焊接速度 Welding Speed	6-18m/min	
生产速度 Production Capacity	15-42cans/min	
适应罐径范围 Can diameter Range	φ 220-φ 300mm	
适应罐高范围 Can Height Range	250-430mm	250-500mm
适应罐身材料 Material	Tinplate 镀锡板 Iron Substrate 钢基板 Galvanized sheet 镀锌板	Tinplate 镀锡板 Steel-based 钢基板 Galvanized sheet 镀锌板 Chrome plate 镀铬板
适应罐身板厚 Tinplate Thickness Range	0.25-0.5mm	
缝焊搭接宽度 Z-bar Overlap Range	0.6mm	0.8mm 1.0mm
焊接点距 Nugget Distance	0.5-0.8mm	
频率范围 Frequency Range	100-260Hz	
铜线直径 Applicable Copper Wire Diameter	φ 1.5mm φ 1.8mm	
冷却水 Cooling Water	温度 Temperature: 12-18°C 压力 Pressure: 0.4-0.5Mpa/m² 流量 Discharge: 12L/min	
压缩空气消耗量 Compressed Air Consumption	400L/min	
空气压力 Pressure	0.5Mpa/m²-0.7Mpa/m²	
电源 Power Supply	380V ± 5% 50Hz	
焊接功率 Total Power	125KVA	
尺寸 Machine Measurements	2300*1800*2000mm	
重量 Weight	4000kg	

样图仅供参考, 实物、参数如有变动恕不通知, 可按客户要求定制产品
Sample figure is only for reference, such as physical parameters, otherwise are subject to change without notice is just for your reference.

AUTOMATIC CAN BODY WELDING MACHINE 全自动罐身变频缝焊机

适用于彩印覆膜桶、花兰桶、方便桶等罐身的焊接

Apply to the welding of various can, such as color printing coated cans, flower orchid cans, convenient cans and so on

可与罐身内、外补涂机和罐身烘干机配套成线

Can body internal and external pre-painting machine and can body drier are optional to be added in production line



FH18-90ZD-30/30L

Technical Parameters 产品参数 产品专利号: 20222096 8273.5

型号 Model	FH18-90ZD-30	FH18-90ZD-30L
订货号 Order number	FH1890ZD3005	FH1890ZD30L05
焊接速度 Welding Speed	6-15m/min	
生产速度 Production Capacity	15-30cans/min	
适应罐径范围 Can diameter Range	φ 220-φ 300mm	
适应罐高范围 Can Height Range	250-430mm	250-500mm
适应罐身材料 Material	Tinplate 镀锡板 Iron Substrate 钢基板 Galvanized sheet 镀锌板	Tinplate 镀锡板 Steel-based 钢基板 Galvanized sheet 镀锌板 Chrome plate 镀铬板
适应罐身板厚 Tinplate Thickness Range	0.25-0.42mm	
缝焊搭接宽度 Z-bar Overlap Range	0.6mm	0.8mm 1.0mm
焊接点距 Nugget Distance	0.5-0.8mm	
频率范围 Frequency Range	100-260Hz	
铜线直径 Copper Wire Diameter	φ 1.5mm φ 1.8mm	
冷却水 Cooling Water	温度 Temperature: 12-18°C 压力 Pressure: 0.4-0.5Mpa 流量 Discharge: 12L/min	
压缩空气消耗量 Compressed Air Consumption	400L/min	
空气压力 Pressure	0.5Mpa/m²-0.7Mpa/m²	
电源 Power Supply	380V ± 5% 50Hz	
焊接功率 Total Power	80KVA	
尺寸 Machine Measurements	2500*1800*2000mm	
重量 Weight	2500kg	

样图仅供参考, 实物、参数如有变动恕不通知, 可按客户要求定制产品
Sample figure is only for reference, such as physical parameters, otherwise are subject to change without notice is just for your reference.

AUTOMATIC CAN BODY WELDING MACHINE

全自动罐身变频缝焊机

适用于20L-60L大桶的焊接，可焊接厚铁皮

Apply to the welding of max 20L-60L big cans with thick tinplate

适用于润华油桶、化肥桶、铁桶凳子、彩印覆膜桶等罐身的焊接

Apply to the welding of various can, such as Runhua oil bucket, fertilizer bucket, bucket stool, color printing film bucket.

可与罐身内、外补涂机和罐身烘干机配套成线

Can body internal and external pre-painting machine and can body drier are optional to be added in production line



FH18-90ZD-25

Technical Parameters产品参数产品专利号: 20222096 8273.5

型号 Model	FH18-90ZD-25
订货号 Order number	FH1890ZD2504
焊接速度 Welding Speed	6-15m/min
生产速度 Production Capacity	15-30cans/min
适应罐径范围 Can Diameter Range	φ 250- φ 360mm
适应罐高范围 Can Height Range	350-700mm
适应罐身材料 Material	Tinplate 镀锡板 Steel-based 钢基板 Galvanized sheet 镀锌板
适应罐身板厚 Tinplate Thickness Range	0.3-0.6mm
缝焊搭接宽度 Z-bar Overlap Range	1mm 2mm 3mm
焊接点距 Nugget Distance	0.5-0.8mm
频率范围 Frequency Range	100-260Hz
铜线直径 Applicable Copper Wire Diameter	φ 1.5mm φ 1.8mm
冷却水 Cooling Water	温度 Temperature: 12-18°C 压力 Pressure: 0.4-0.5Mpa/m² 流量 Discharge: 16L/min
压缩空气消耗量 Compressed Air Consumption	400L/min
空气压力 Pressure	0.5Mpa/m²-0.7Mpa/m²
电源 Power Supply	380V±5% 50Hz
焊接功率 Total Power	180KVA
尺寸 Machine Measurements	2500*1800*2000mm
重量 Weight	4500kg

样图仅供参考，实物、参数如有变动恕不通知，可按客户要求定制产品
Sample figure is only for reference, such as physical parameters, otherwise are subject to change without notice is just for your reference.

COATING MACHINE

外补涂机



GNWT-286S/180S

与焊机连接，采用悬臂式上吸同步带输送设计，便于喷粉，前端压缩空气冷却焊缝，避免焊缝温度过高时结块或起胶。

Connected with the welding machine, the cantilever upward suction belt conveying design is convenient for powder spraying, and the front compressed air cools the weld seam to avoid powder agglomeration or glue foaming when the weld seam temperature is too high.

输送采用进口同步带，焊接罐体吸在输送带下，改变罐型时无需调整输送高度，输送平稳。

Imported belt is used for conveying, and the welded can body is sucked under the conveyor belt, so that there is no need to adjust the conveying height when changing the can type, and the conveying is stable.

外涂胶带胶轮和补涂轮两侧均装有清洗板，使胶水不污染涂胶轮侧面，保证涂轮的清洁度。

Cleaning plates are installed on both sides of the outer coating belt rubber wheel and the roller, so that the glue does not pollute the side of the coating wheel and ensures the cleanliness of the coating wheel.

Technical Parameters产品参数产品专利号: 20222096 8273.5

型号 Model	GNWT-286S	GNWT-180S
订货号 Order number	GNWT286S01	GNWT180S02
补涂速度 Roller Speed	5-30m/min	
补涂宽度 Lacquer width	10-20mm	8-15mm
适应罐径 Can Diameter sizes	φ 200- φ 400mm	φ 52- φ 180mm
补涂方式 Coating Type	Roller spraying 滚涂 / spraying spraying 喷涂	
功率 Current load	0.75KW	
电源 Powder Supply	220V	
压缩空气压力 Air consumption	0.6Mpa/m² 20L/min	
外形尺寸 Machine Measurements	2100*720*1520mm	
重量 Weight	400kg	

样图仅供参考，实物、参数如有变动恕不通知，可按客户要求定制产品
Sample figure is only for reference, such as physical parameters, otherwise are subject to change without notice is just for your reference.

WHOLE LINE PRODUCTION

整线生产

适用于食品罐、气雾罐、化工罐、覆膜铁、钢桶凳子等罐身的焊接、粉末补涂、烘干等。

Can be used for food cans, chemical cans and square bucket of can body welding, roller coating, drying.

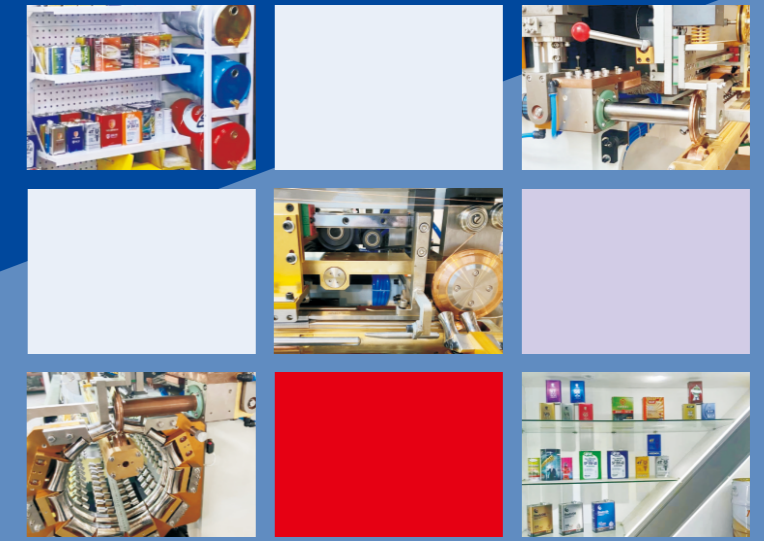

样图仅供参考，实物、参数如有变动恕不通知，可按客户要求定制产品
Sample figure is only for reference, such as physical parameters, otherwise are subject to change without notice is just for your reference.

POWDER SYSTEM

粉末喷涂机

适用于食品罐、饮料罐、化工罐等焊缝的补涂。

Apply to the seam weld coating for food cans ,drink cans ,chemical cans etc.

可选全自动或者半自动罐身分缝焊机、烘干机配套成线。

Automatic can body welding machine or semi-automatic body welding machine and drying machine are optional to be added in production line.

可根据生产速度调节粉量和雾化量粉末喷涂更均匀，防锈效果更好。

Powder coating is more uniform and better for protecting the seam weld from rust.

粉末自动循环，避免喷粉结束后取出粉末。

Powder automatic circulation;avoid removing powder out after finished spraying.

粉末热风流化，防止粉末潮湿结块。

Hot air fluidization to prevent powder to be damp and agglomeration.

喷粉后自动清理

Automatic clean after finished spraying



CTPC-2

Technical Parameters 技术参数

型号 Model	CTPC-2	
订货号 Order number	CTPC201	
喷涂速度 Production Speed	5-60m/min	
喷涂宽度 Powder Width	8-10mm	10-20mm
适应罐径 Can Body Range	φ 50- φ 200mm	φ 80- φ 400mm
功率 Power	2.8KW	
电源 Power Supply	380V+N+PE	
压缩空气压力 Air consumption	0.6Mpa/m ²	
压缩空气消耗量 Air Requirement	100-200L/min	
外形尺寸 Machine Measurements	1080*720*1820mm	
重量 Weight	350kg	

样图仅供参考，实物、参数如有变动恕不通知，可按客户要求定制产品

Sample figure is only for reference,such as physical parameters,otherwise are subject to change without notice is just for your reference.

HIGH FREQUENCY ELECTROMAGNETIC DRYER

高频电磁烘干机

适用于气雾罐，食品罐，化工罐，彩印覆膜铁等罐身补涂后的烘干

Apply to the drying after coating of various can aerosol cans ,food cans, beverage cans, chemical cans.

可与全自动或者半自动罐身缝焊机，内外补涂机配套成线。

Automatic can body welding machine or semi-automatic body welding machine and external internal coating machine are optional to be added in production line.

感应加热无需冷却水

The induction heating head without cooling water

每节感应头功率可单独调节

Each section of the sensor head powder can be adjusted independently

有效加热长度为每节800mm，有效加热长度可根据生产速度调整。

The effective heating length is 800mm/section;the effective heating length can be adjusted according to the production speed.

烘干机可根据客户场地设计，定制产品。

Dryers can design according to customer's site, customized products.



Technical Parameters 产品参数 产品专利号: 20222083 0556.3

型号 Model	GDCHG-180/286-8	GDCHG-180/286-12	GDCHG-180/286-15
订货号 Order number	GDCHG21802860801	GDCHG21802861202	GDCHG21802861503
输送长度 Conveyor Speed	9-18m/min	12-22m/min	12-24m/min
输送方式 Conveyor Type	Up-sucking delivery 上吸式输送		
适应罐径 Can Height Range	φ 52- φ 180mm / φ 220- φ 300 mm	φ 220- φ 300mm	φ 220- φ 300mm
加热方式 Heating Type	高频电磁感应罐身产生涡流发热 High frequency electromagnetic dryer can body generates eddy heat		
加热有效长度 Effective Heating	800mm*8	800mm*12	800mm*15
加热最大功率 Higher Heating	1KW*8(temperature set)	1KW*12(temperature set)	1KW*15(temperature set)
高频频率 Frequency Setting	80KHz ± 10 KHz		
电磁辐射屏蔽方式 Electro.Radiation Protective	金属外罩门 Covered with safety guards		
有效感应距离 Sensing Distance	5-20mm		
有效加热宽度 Induction Point	40mm		
电源 Power Supply	380V +N 8KVA	380V +N 12KVA	380V +N 15KVA
胶水烘干温度及时间	260℃，加热时间15秒(温度分段可调) 根据客户需求温度可独立调节		
升温速度 Rise time(MAX)	The temperature can be adjusted independently according to customer demand Distance 5mm 8sec&280℃ Distance 5mm 12sec&280℃ Distance 5mm 15sec&280℃		
加热头冷却方式 Cooling Diduct.Coil	自然冷却 Not require water/air		
外形尺寸 Demension	6380*750*1420mm	12760*850*1420mm	15000*850*1420mm
重量 Weight	850KG	1700KG	2200KG

样图仅供参考，实物、参数如有变动恕不通知，可按客户要求定制产品

Sample figure is only for reference,such as physical parameters,otherwise are subject to change without notice is just for your reference.

ELECTROMAGNETIC INDUCTION DRYING HEADPHONES 电磁感应烘耳机

适用于10-20L花兰桶耳朵补胶后的烘干
Suitable for drying 10-20L cans ears after gluing



- 根据客户罐身高度，只需输入罐的实际高度，机器自动上升或下降到所需高度。无需人工操作。
According to the customer tank body height, just input the actual height of the tank, the machine will automatically rise or fall to the required height. No slave operation required.
- 每个工位都是实时检测罐身温度，当温度达到设定温度时，自动恒温，有效防止因不同感应头调节功率不一样时，造成过烘变色。
Each station is real-time detection of tank body temperature, when the temperature reaches the set temperature, automatic constant temperature, effectively prevent because of different induction head adjustment power is not the same, resulting in overdrying discoloration.
- 为防止温度传感器的损坏，机器具有按设置温度一键设定加热时间功能。
In order to prevent the damage of the temperature sensor, the machine has the function of pressing the setting temperature to set the heating time.
- 桶内环形加热，耳朵在任何方向不受影响。
The barrel ring heating, ears in any direction is not affected.
- 具有出罐处温度不能达到设定值的剔除功能，防止烘不干的罐身进入下道工序。
With the removal function of the temperature at the tank can not reach the set value, to prevent the dry tank body into the next process.

Technical Parameters产品参数

型号 Model	GDCHG-TE-272-12	GDCHG-TE-272-18	有效加热宽度 Induction point	提耳定位 80mm Teal positioning 80mm
订货号 Order number	GDCHGTE2721201	GDCHGTE2721202		
烘干速度 Drying Speed	20-42cans/min	40-60cans/min	适应罐径 Applicable diameter range	80-286mm
输送方式 Conveyor Type	旋转式，共中心线进出罐 Rotary, common center line in and out of the cans		温度及时间 Temperature and time	10秒 220℃ 220℃ in 10 seconds
控制方式 Control Mode	按设定温度恒温控制 Constant temperature control according to the set temperature		电源 Power supply	380V +N 20KVA
加热方式 Heating Type	内部整圈感应加热 Internal full circle induction heating		压缩空气 Compressed air	0.6MPa/m ² 300L/min
加热最大功率 Maximum Heating	0.4KW*12 温度每段独立调节 Temperature is adjusted independently for each section	0.4KW*18 温度每段独立调节 Temperature is adjusted independently for each section	电磁辐射屏蔽方式 Electro.Radiation protective	金属外罩门 Covered with safety guards
重量 Weight	3000KG	3500KG	高频频率 High frequency	80KHz±10KHz
外形尺寸 Demension	2100mm*2280mm*2380mm	3600mm*2700mm*2380mm	加热头冷却方式 Cooling diduct. coil	自然冷却 Not require water/air

样图仅供参考，实物、参数如有变动恕不通知，可按客户要求定制产品
Sample figure is only for reference,such as physical parameters,otherwise are subject to change without notice is just for your reference.

PALLETIZER 码垛机

适用于18-20L花兰桶码垛

The palletizer is suitable for 18-20L metal cans

与电磁感应烘耳机配套使用

It is used with the Electromagnetic induction drying headphones



Technical Parameters产品参数

型号 Model	单通道 Single channel	双通道 Dual channel
		GDT-272-40
订货号 Order number	GDT27201	GDT27202
输送速度 Conveyor Speed	20-40cans/min	30-60cans/min
适应罐径 Can Height Range	272mm	
功率 power	380V+N 5KW	380V+N 5KW
压缩空气 Compressed Air	0.6MPa/m ²	
重量 Weight	2800KG	3000KG
外形尺寸 Demension	6080mm*1500mm*4100mm	6580mm*1800mm*4100mm

样图仅供参考，实物、参数如有变动恕不通知，可按客户要求定制产品
Sample figure is only for reference,such as physical parameters,otherwise are subject to change without notice is just for your reference.

SEMI-AUTOMATIC CAN BODY WELDING MACHINE 半自动罐身变频缝焊机

适用于手电筒、小气雾罐罐身的焊接
Apply to the welding of various can flashlight, small aerosol cans

可与罐身内、外补涂机和烘干机配套成线

Can body internal and external pre-painting machine and can body drier are optional to be added in production line.

可根据客户需要加快速度

According to customer's demands to accelerate the speed.

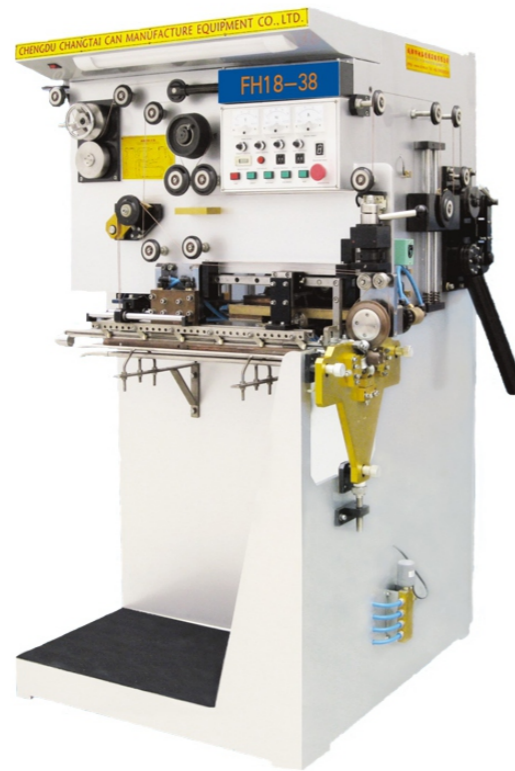

FH18-38

Technical Parameters 产品参数 产品专利号: 20222096 8273.5

型号 Model	FH18-38
订货号 Order number	FH183801
焊接速度 Welding Speed	6-18m/min
生产速度 Production Capacity	20-80cans/min
适应罐径范围 Can diameter Range	38-45mm
适应罐高范围 Can Height Range	70-320mm
适应罐身材料 Material	Tinplate 镀锡板 Steel-based 钢板 Chrome plate 镀铬板
适应罐身板厚 Tinplate Thickness Range	0.18-0.35mm
焊接点距 Seam Point Distance	1.38mm
冷却水 Cooling Water	Temperature 12-18℃ Pressure: 0.4-0.5Mpa Discharge: 7L/min
电源 Power Supply	380V±5% 50Hz
装机容量 Total Power	18KVA
尺寸 Machine Measurements	1200*1100*1800
重量 Weight	1500kg

样图仅供参考, 实物、参数如有变动恕不通知, 可按客户要求定制产品
Sample figure is only for reference, such as physical parameters, otherwise are subject to change without notice is just for your reference.

AUTOMATIC ROUND-FORMING MACHINE 全自动卷圆机

Technical Parameters 产品参数

型号 Model	ZDJY80-330	ZDJY45-450
订货号 Order number	ZDJY8033001	ZDJY4545002
生产速度 Production Capacity	10-80cans/min	5-45cans/min
适应罐径范围 Can Diameter Range	φ 70- φ 180mm	φ 99- φ 300mm
适应罐高范围 Can Height Range	70-330mm	100-450mm
适应罐身材料 Material	镀锡板 Tinplate/铜基板 steel-based/镀铬板 chrome plate	
适应罐身板厚 Tinplate Thickness Range	0.15-0.42mm	
压缩空气消耗量 Compressed air consumption	200L/min	
压缩空气气压 Pressure of Compressed air	0.5Mpa/m²-0.7Mpa/m²	
电源 Power Supply	380V±5% 50Hz 2.2Kw	
尺寸 Machine Measurements	2100*720*1520mm	



ZDJY80-330/450

样图仅供参考, 实物、参数如有变动恕不通知, 可按客户要求定制产品
Sample figure is only for reference, such as physical parameters, otherwise are subject to change without notice is just for your reference.

FIXED PIN GAUGE 定径规

缝焊机主要配件之一

One of major accessories in welding machine, high quality
可根据客户需求定制

Be able to process various parts as per customer's sample

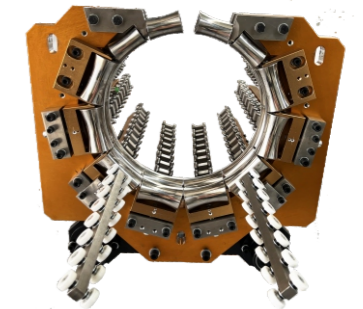

INDUSTRIAL CHILLER 冷水机

可与缝焊机配套成线

But with welding seam supporting into line

型号 Model	YMWC-3P	YMWC-5P
订货号 Order number	YMWC3P	YMWC5P
制冷量 Refrigerating Capacity	7800 KCAL	13000 KCAL
水泵功率 Pump Power	0.55 KW	0.75 KW
冷媒 refrigerant	R22	
压缩机功率 Compressor Power	3.48 KW	
水压力 Water Pressure	4Kg/cm²	8Kg/cm²
电压 voltage	380V+N	
水流量 Water Flow	4T	3T



18-20L花兰桶生产线布线图

18-20L FLOWER ORCHID BARREL PRODUCTION LINE WIRING DIAGRAM

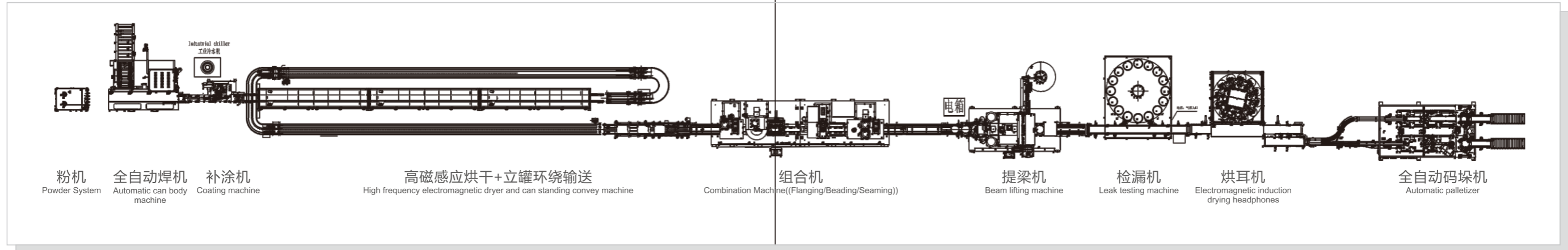

1-10L方罐生产线布线图

WIRING DIAGRAM OF 1-10L SQUARE TANK PRODUCTION LINE

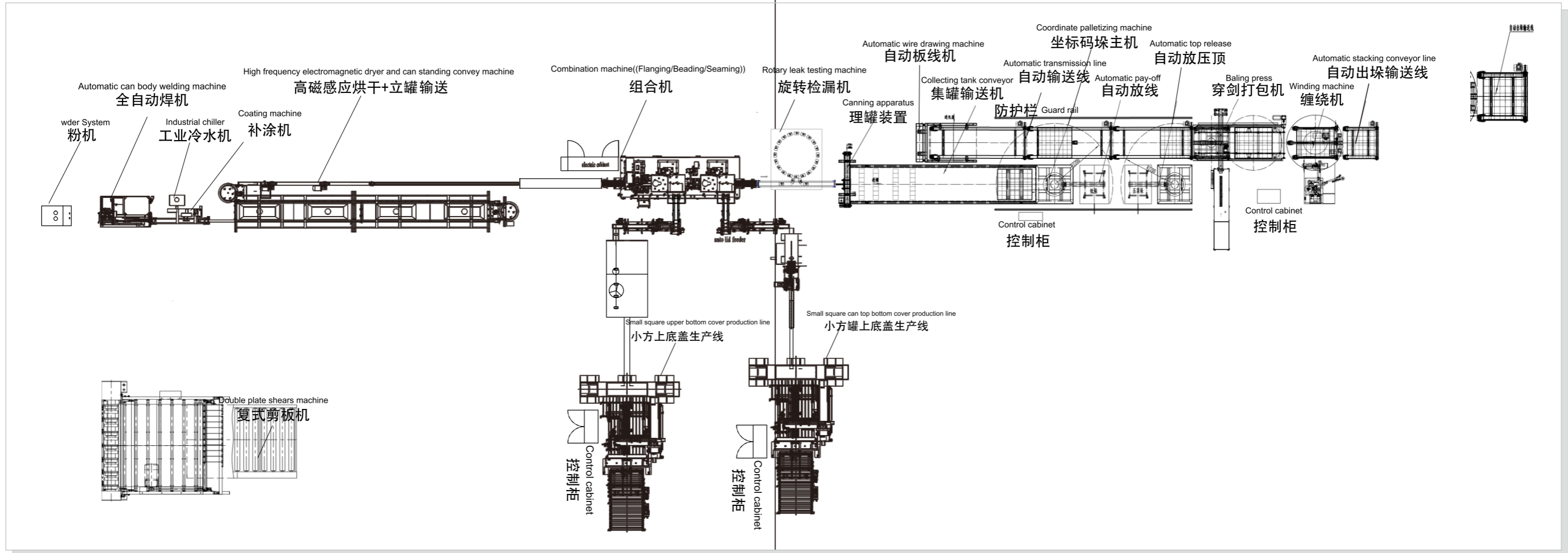



COOPERATIVE PARTNER
合作伙伴



甘肃科技投资集团有限公司
GANSU SCIENCE AND TECHNOLOGY INVESTMENT GROUP CO.,LTD.



国内官网: <http://www.changtaizn.cn/>



Google website: <https://www.ctcanmachine.com/>

